

WISH BONE SPLITTER INSTRUCTIONS

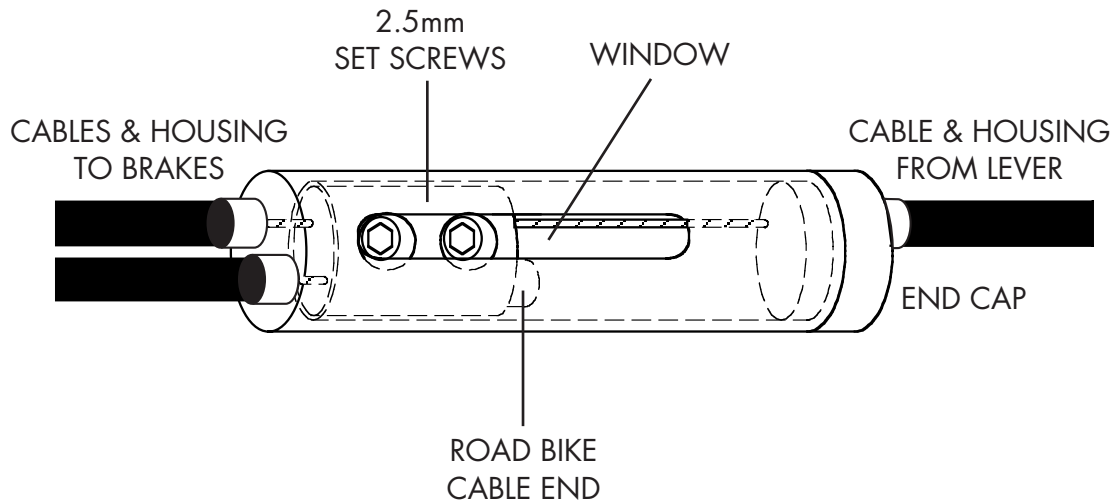

1. Assemble the components as shown. (Ferrules are not supplied.)
Do not tighten the set screws.
The splitter replaces 2" of housing of the existing "through" cable.
2. Adjust and tighten the through cable.
3. Remove slack and adjust the secondary cable.
4. Tighten the set screws.



FOR CUSTOMER SERVICE PLEASE PHONE: 1 (909) 596-7570 x72